

DSP21SUB

240W 10" Commercial Surface Mount Subwoofer



Description

The DSP21SUB is a 240W in-ceiling subwoofer designed to deliver excellent sound quality and powerful low-frequency performance. With its simple structure and convenient power configuration, it is easy to install and operate. Ideal for indoor environments, it enhances background music systems and voice broadcasting applications with rich and dynamic bass.

Features

- 10-inch woofer for powerful low-frequency performance
- 70V / 100V / 4Ω selectable, Rated Power: 240W
- Frequency Response: 36 Hz – 150 Hz
- Sensitivity: 89 dB
- Product Dimensions: $\phi 360 \times 330$ mm
- Material: ABS speaker grille with iron speaker enclosure
- Color: White grille with matte black enclosure

Specifications

Model	DSP21SUB
Rated Power	240W
Driver Units	10" Woofer

Max Power		480W
Power Adjustment	100V	240W-120W-60W
	70V	120W-60W-30W
	4Ω	240W
Sensitivity		89dB
Frequency Response(-10dB)		36-150Hz
Coverage angle(1KHz/-6dB)		180°
Color		White Speaker Cover+ Matt Black Speaker Body
Product Size(W*D)		Φ360 *330mm
Package Size (L*W*H)		450*450*430mm
Net Weight		9.5kg
Gross Weight		12.7kg

Product Information

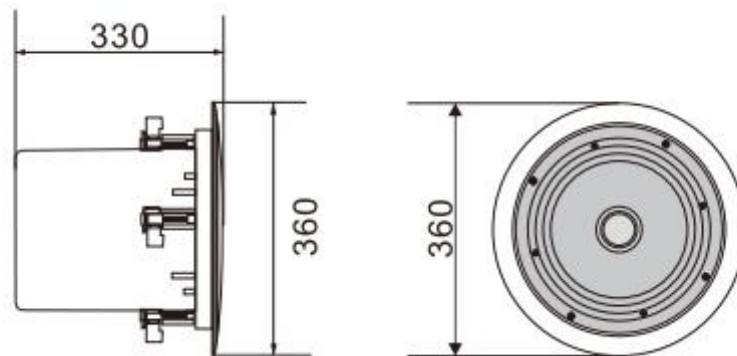

Installation Steps

Step 1: Open a $\phi 330$ mm hole in the ceiling.

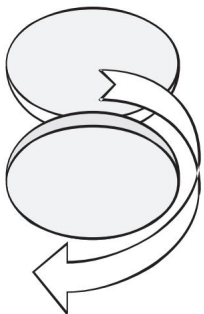

Step 2: Remove the mesh mask.

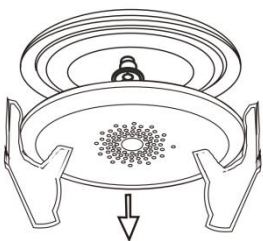

Step 3: Press the open hole in advance, install the product to the ceiling, and lock the screws.

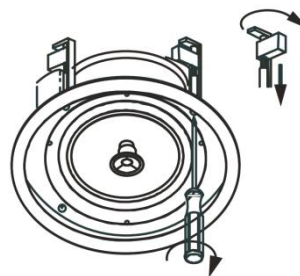

Step 4: After the product is fixed, reload the mesh mask.

